



# COLORDMD

Installation Instructions  
for **Gottlieb**® - CHROMA LED

Congratulations on the purchase of a new ColorDMD display. The ColorDMD will enhance your pinball machine by introducing *color* to the dot matrix display graphics produced by the game.

- Tools Required:
- 5/16" Nut Driver
  - 3/8" Nut Driver
  - Phillips Screwdriver



Be sure to turn **OFF** the power to the pinball machine before installing the ColorDMD display.

- STEP **1** Carefully remove the translite from the backbox and then lower the speaker panel to the position shown in Fig. A to gain access to the backbox.

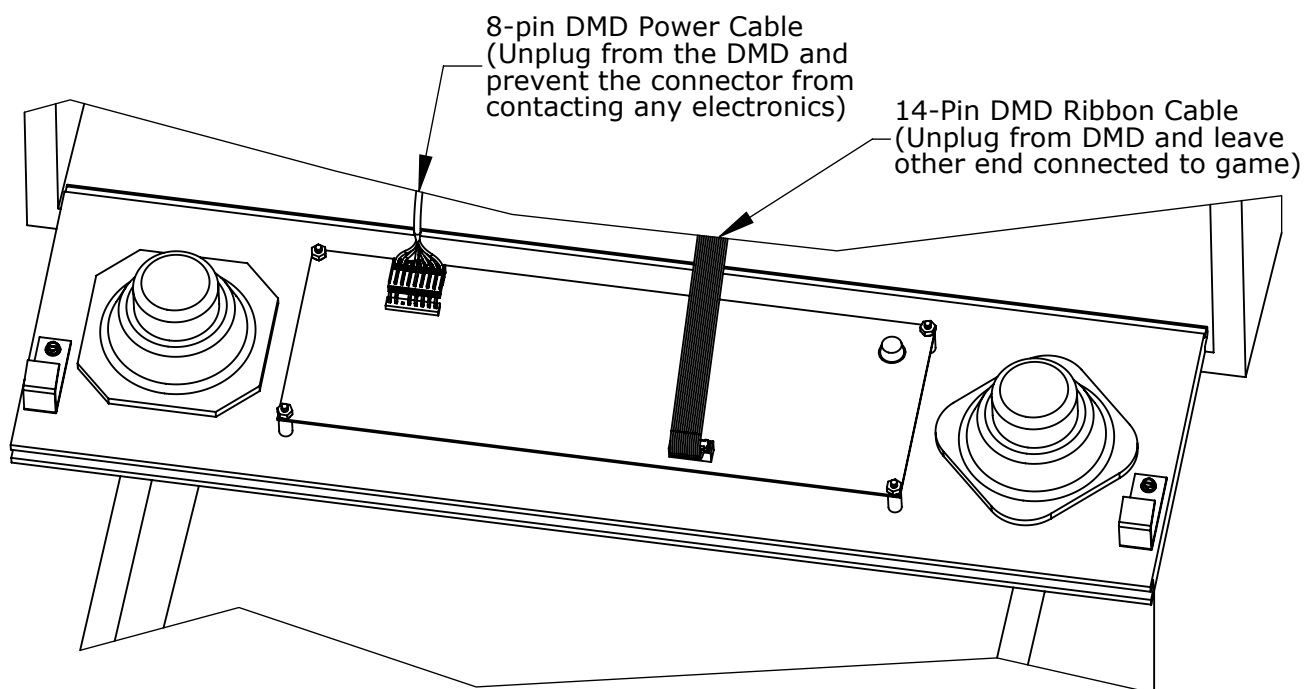

Figure A

- STEP **2** Disconnect the DMD power and ribbon cables from the DMD (see Fig. A). **Secure the DMD Power Cable in a position and location that will prevent it from contacting any electronics.**

- STEP **3** Remove and save all of the original DMD mounting hardware. **Remove the original DMD assembly from the game and store it in a safe place.**

- STEP **4** If pinball machine has a transparent colored plastic film attached to the wooden speaker panel, carefully remove and store it with original DMD. If the speaker panel plastic has red translucent paint covering the viewable DMD area, it must be removed.

STEP **5** Remove the protective film from the front side of the new ColorDMD display.

STEP **6** Install one of the provided 1/4" Nylon spacers on each of the four threaded studs. Position the ColorDMD face down on the speaker panel (centered in the orientation shown in Fig. B).

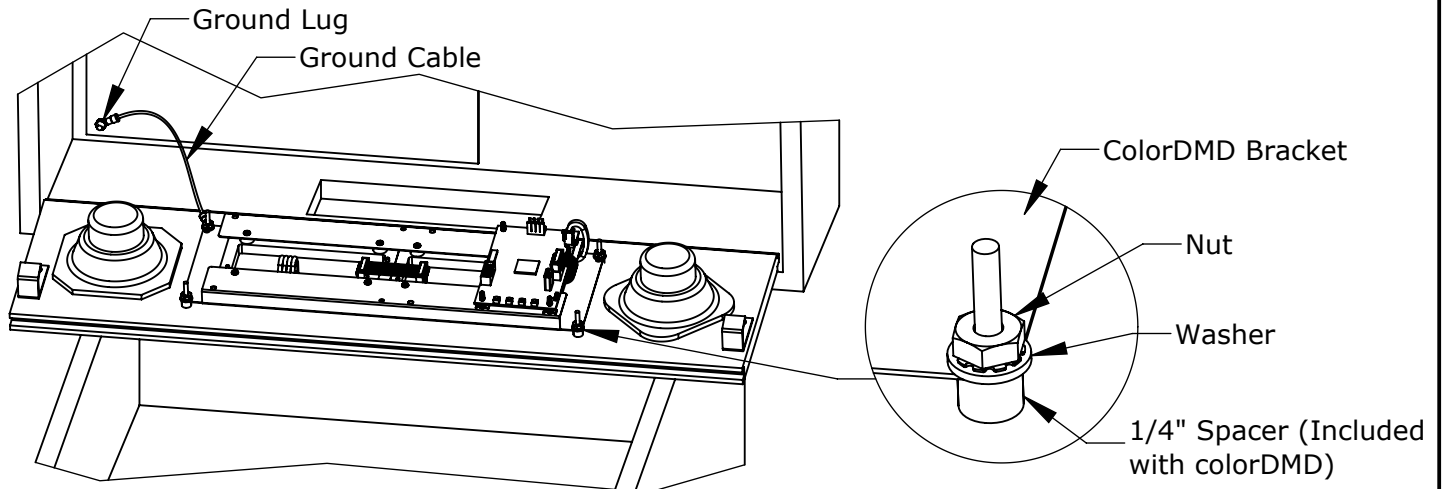

Figure B

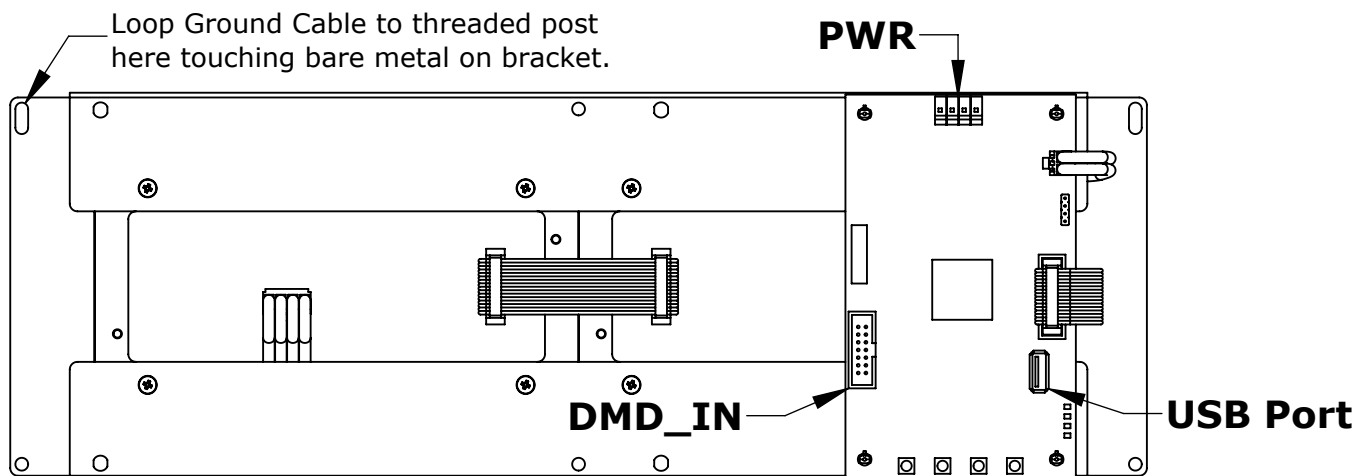

Figure C

STEP **7** Locate the included green ColorDMD ground cable and connect larger ring end to the Ground Lug in the backbox (see Fig. B). Loop the other end of the cable over the threaded stud nearest to the Ground Lug on the bracket's bare metal area (see Fig. C).

STEP **8** Use the original DMD mounting hardware from Step 3 to fasten the ColorDMD display to the speaker panel. See Fig. B for correct stacking order of the hardware.



**WARNING. Electric Shock Hazard** - To protect against accidental electric shock, **DO NOT** operate the game without ensuring that the ColorDMD metal bracket is electrically grounded.

STEP **9**

Locate the included ColorDMD Power Cable. One end of the cable has a single connector (see Fig. D). Plug this connector into the PWR header (see Fig. C) on the ColorDMD circuit board and connect the System 3 Power Adapter to the other end (see Fig. D).

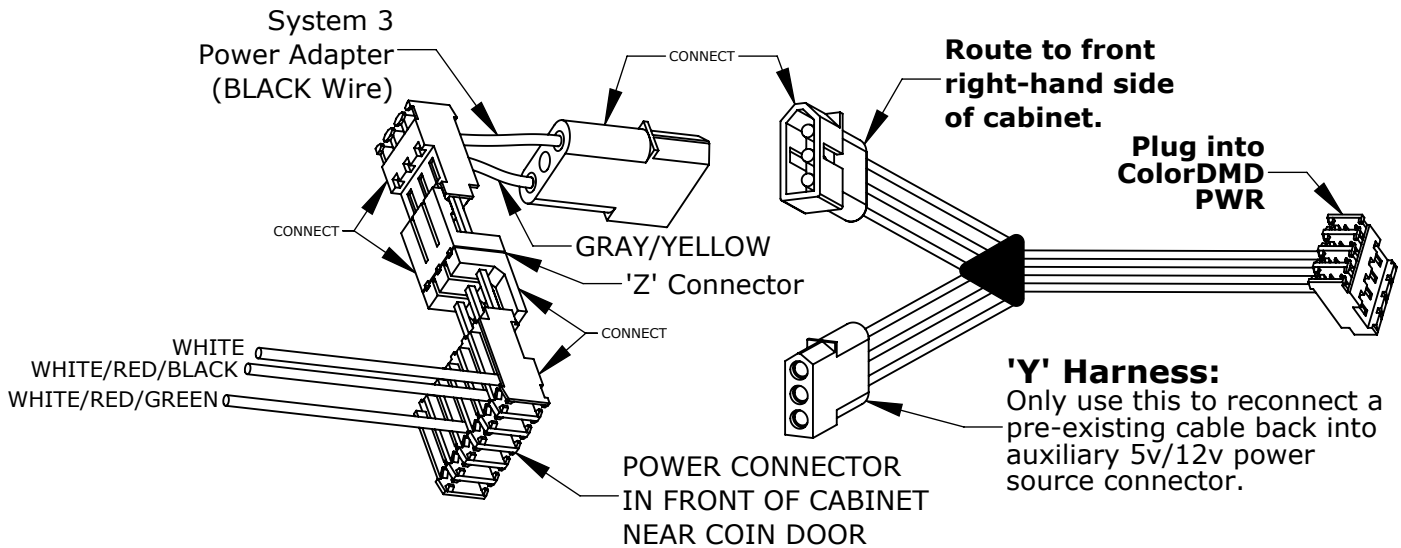

Figure D

STEP **10**

Route the other end of the new ColorDMD Power Cable down through bottom of backbox into the cabinet and over to the front right-hand side of the game. (see Fig. E).

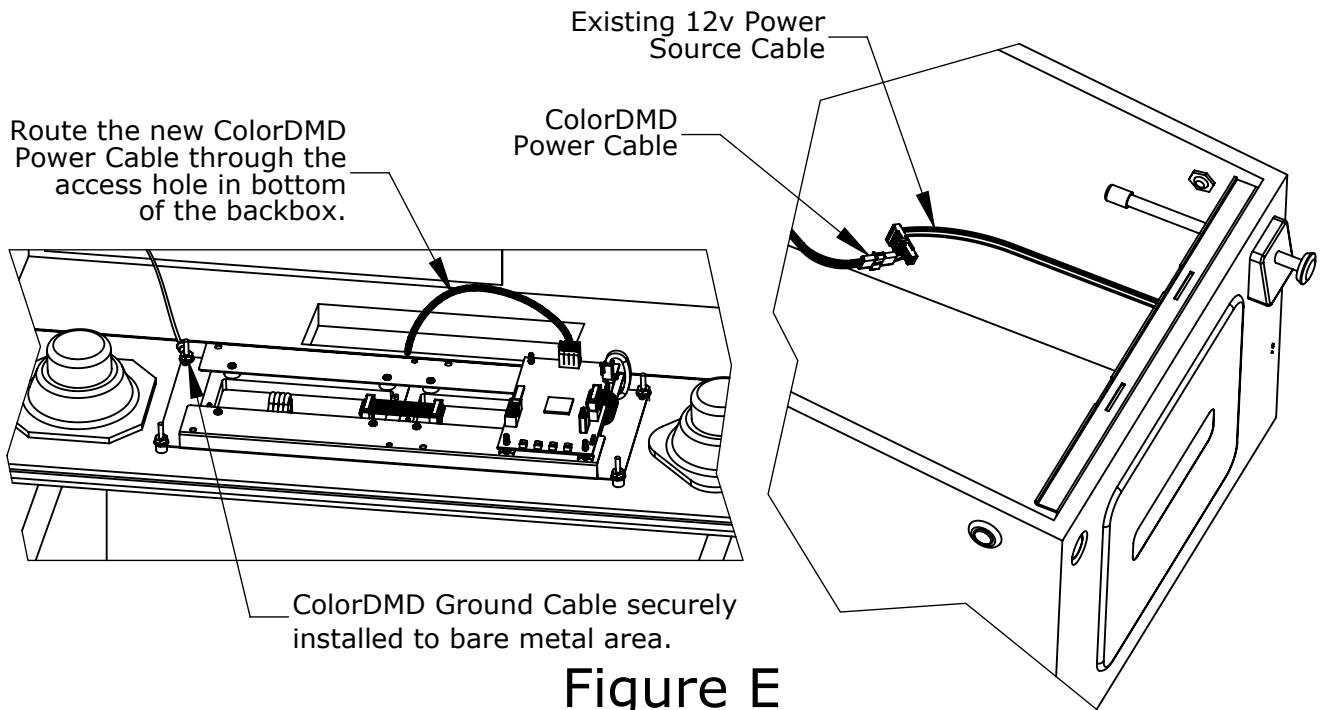

Figure E

STEP **11**

Using the 3-pin 'Z' Connector, attach the Gottlieb Adapter to the 6-pin connector located in the front of the cabinet near the coin door (see Fig. E). Correct connector alignment will have the BLACK wire of Gottlieb Adapter going to the WHITE wire of the power connector in the cabinet (see Fig. D).

- STEP **12** Plug the 14-Pin ribbon cable into DMD\_IN on the ColorDMD with the **red stripe nearest the four buttons** of the speaker panel (see Fig. F). The other end of this cable should still be plugged into C7 on the DMD Controller Board with red stripe facing down.

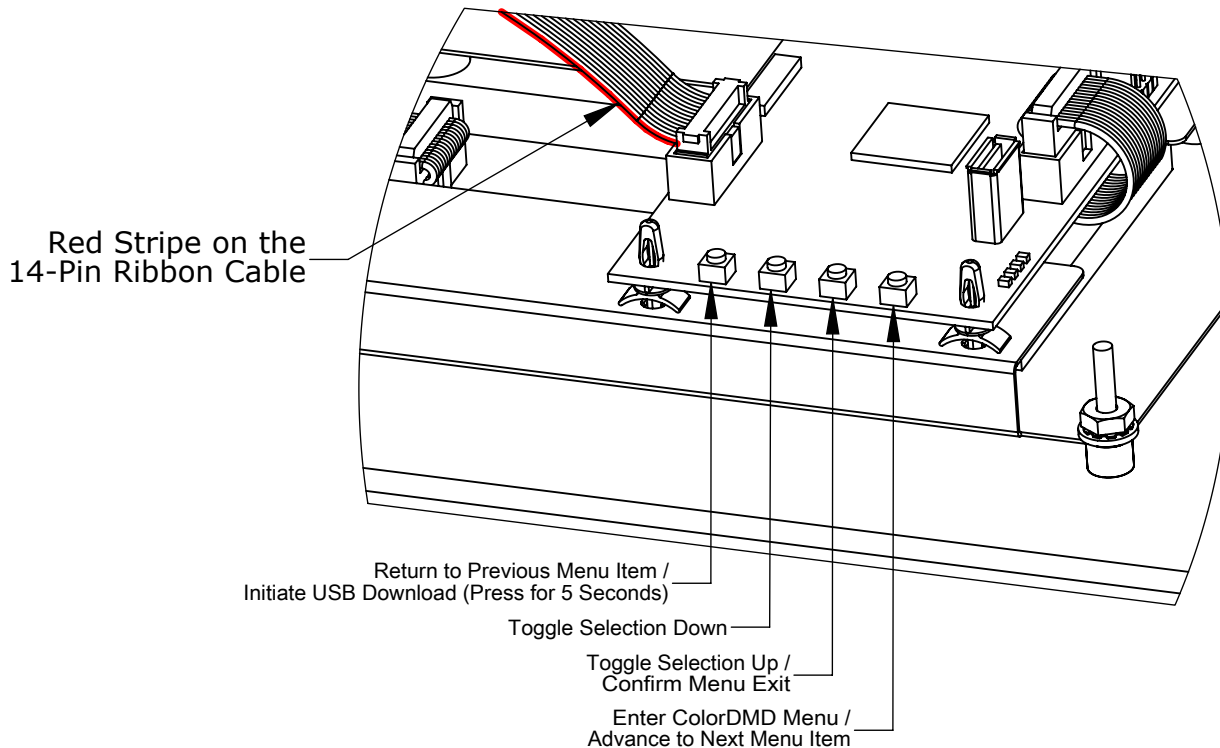

Figure F

**!** *Double check for proper alignment of **all** cable connections.*

- STEP **13** While ensuring no wires get pinched, raise the speaker panel and turn on the pinball machine.
- STEP **14** Locate and press the right-most *ColorDMD Menu* button (See Fig. F) to customize the display settings. Continue pressing the button to advance to the "MOUNTING" menu. Next use the *Toggle Selection Up* button to change the setting to "GOT".
- STEP **15** Press the right-most button to advance to the "EXIT AND SAVE" menu. Press the *Confirm Menu Exit* button to save settings and return to game mode. Video should appear on the new ColorDMD Display. Game is now ready to play. Have fun!

For additional information regarding display settings and to download game specific color ROM files, please visit our website at [www.colordmd.com](http://www.colordmd.com).