



COLORDMD

Installation Instructions for **SEGA** (wooden speaker panel)

Congratulations on the purchase of your new ColorDMD display. The ColorDMD will enhance your pinball machine by introducing *color* to the dot matrix display graphics produced by the game.

- Tools Required:
- 5/16" Nut Driver
 - Phillips Screwdriver
 - Dremel tool with 1/4" cutoff wheel
 - Towels and/or masking tape to protect clear DMD lens



Be sure to turn **OFF** the power to the pinball machine before installing the ColorDMD display.

- STEP **1** Carefully remove the translite from the backbox and then swing speaker panel to the open position as shown in Fig. A to gain access to the DMD.

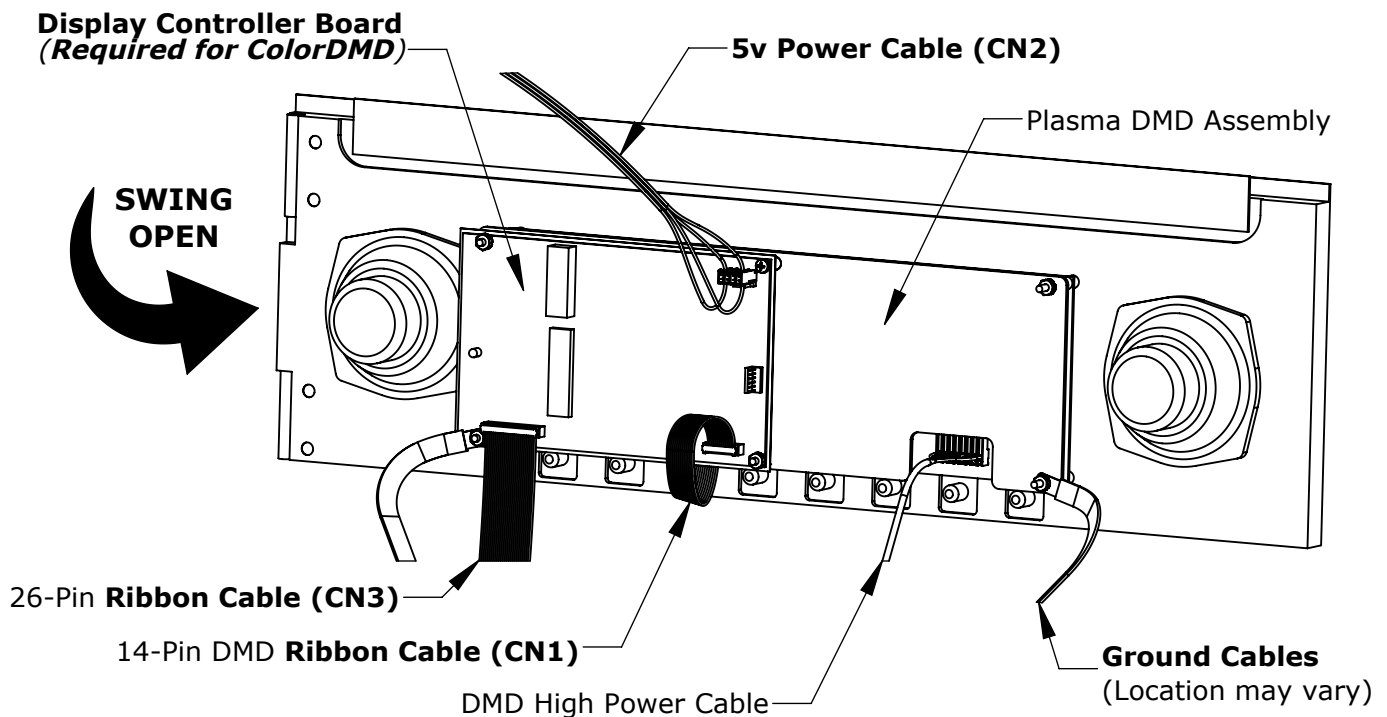

Figure A

- STEP **2** Disconnect the DMD High Power Cable from the DMD and secure it aside (it is not used for the ColorDMD). Insulate the disconnected end of this cable with electrical tape. Also disconnect the 5v power cable at CN2 on Display Controller Board.
- STEP **3** Disconnect the ribbon cables from CN1 and CN3 on the Display Controller Board. **Remove the Display Controller Board from the metal bracket on the DMD assembly.**
- STEP **4** Remove the five DMD assembly mounting screws and/or nuts. **Remove the original DMD assembly from the game and store it in a safe place.**

STEP **5** **Preparing the speaker panel to mount the ColorDMD.**

Protect both sides of the clear plastic lens on the speaker panel and all surroundings with towels and/or masking tape to prevent damage.

Using a Dremel tool with a 1¼" diameter cutoff wheel, **carefully cut the center threaded post so that it is completely flush with plastic speaker panel** (see Fig. B).

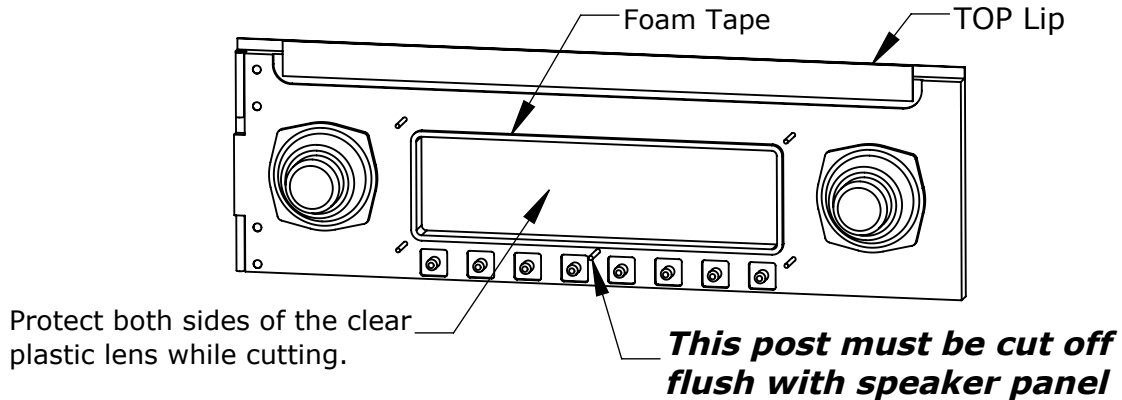

Figure B

STEP **6** **Installing the ColorDMD Power Tap.**

Temporarily remove the game's 15-pin power cable connector from J16 on the Power Supply Circuit Board located inside the backbox (See Fig. C).

1. Attach the ColorDMD Power Harness to the ColorDMD Power Tap (see Fig. D).
2. Install the ColorDMD Power Tap to J16 (See Fig. D). The ColorDMD Power Tap is keyed and will only install one way.
3. Attach the game's 15-pin power cable connector to the ColorDMD Power Tap (See Fig. D). The 15-pin power cable is keyed and will only install one way.

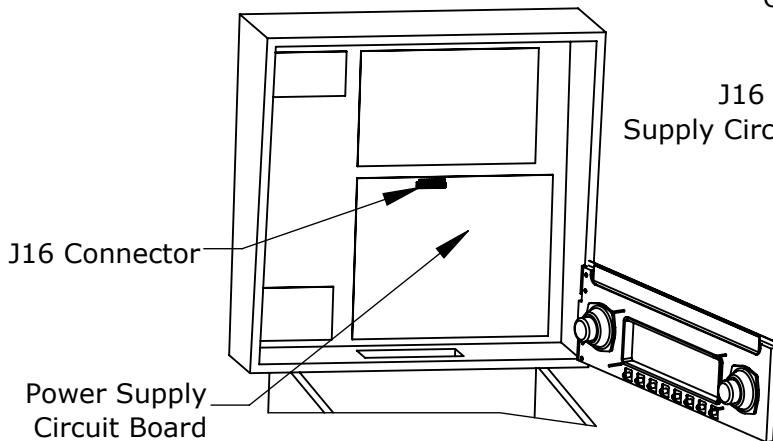

Figure C

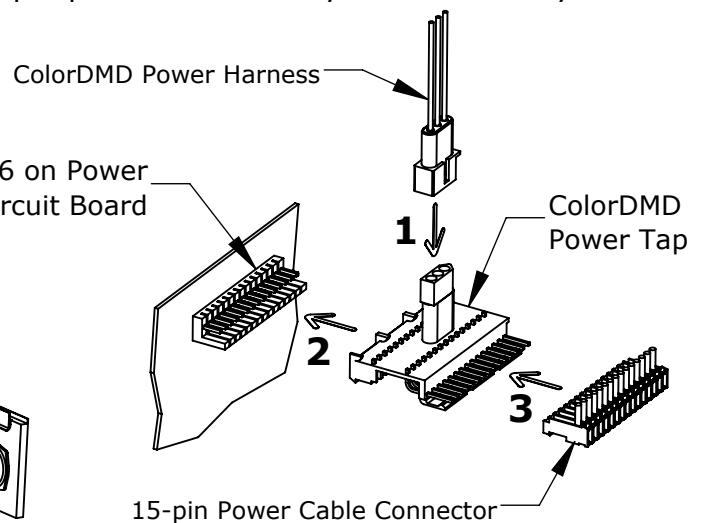

Figure D



Route all power cables to ensure there is no stress on the connections to the ColorDMD Power Tap.

- STEP **7** **Ensure the RF Shield (if present) remains under the Display Controller Board with metallic side facing down.** Using the 4 screws supplied in the ColorDMD mounting bracket, fasten the Display Controller Board to the ColorDMD in the orientation shown in Fig. E.

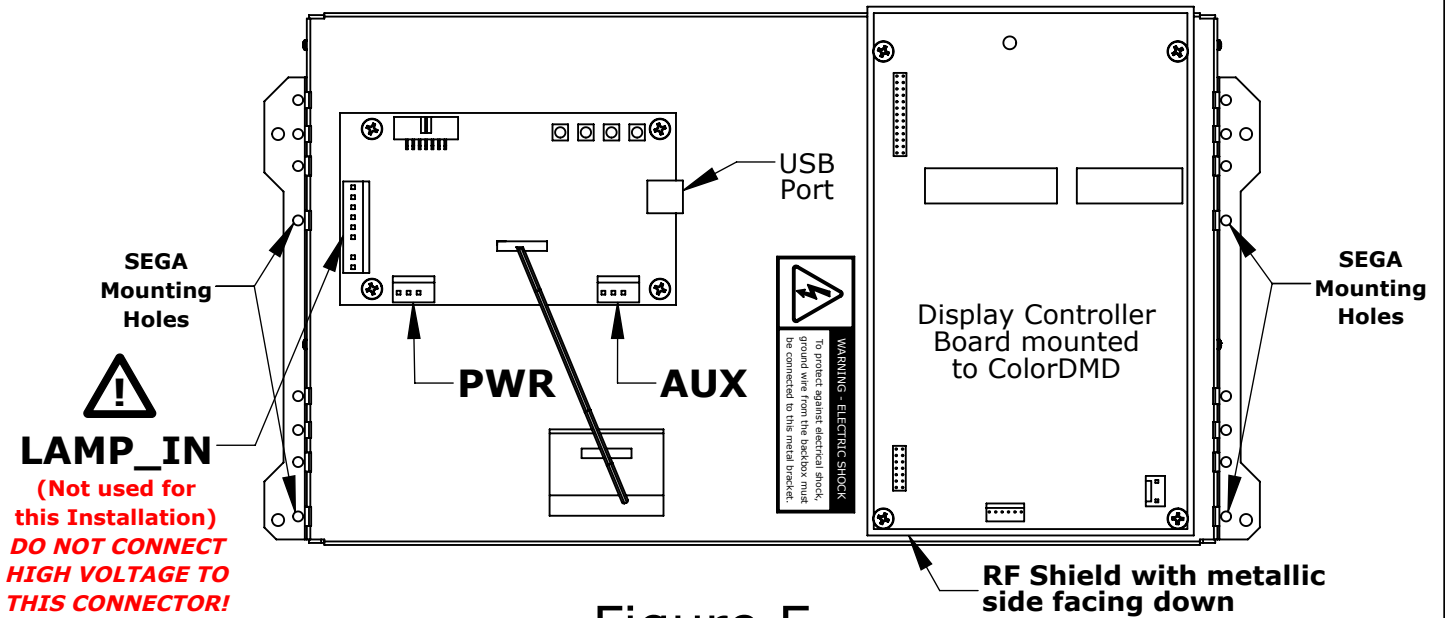

Figure E

- STEP **8** Remove the protective film from the front side of the new ColorDMD display.
- STEP **9** Install one 1/4" Spacer on each of the four threaded posts and then position the ColorDMD face down (centered in the orientation shown in Fig. F) and align the SEGA mounting holes (see Fig. E).

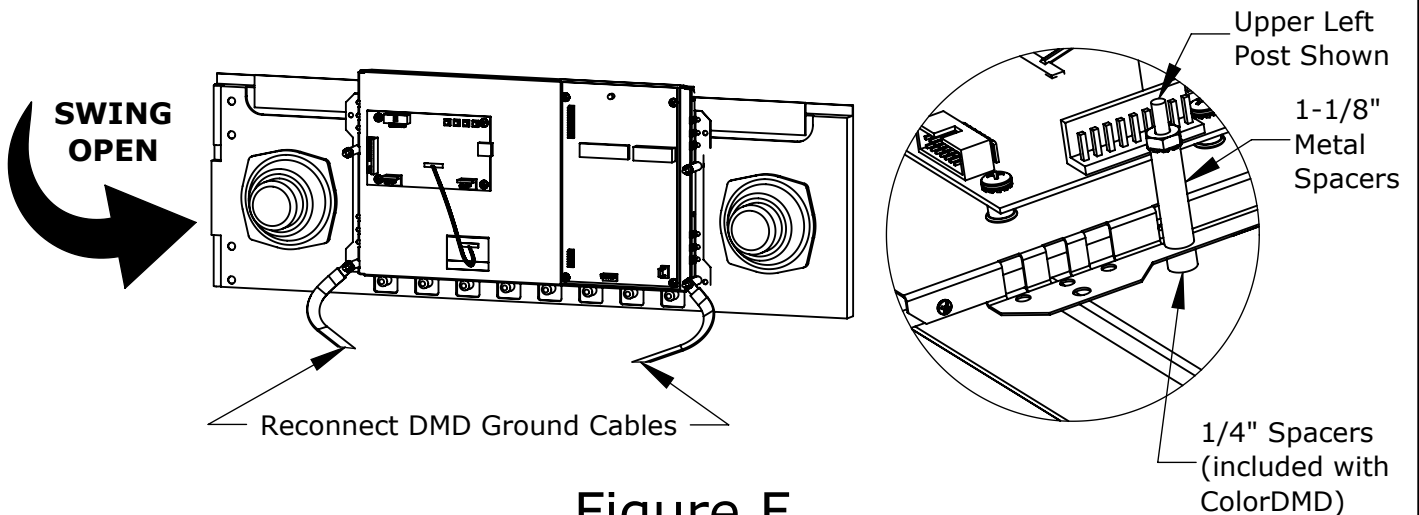

Figure F

- STEP **10** Place one of the existing 1-1/8" long metal spacers over each threaded post and secure the ColorDMD with four of the existing nuts. **Make sure to reconnect the DMD Ground Cables to ColorDMD** (see Fig. F).



WARNING. Electric Shock Hazard - To protect against accidental electric shock, **DO NOT** operate the game without ensuring that the ColorDMD metal bracket is electrically grounded.

STEP **11** One end of the included ColorDMD Power Harness has a single connector (see Fig. G). Plug this connector into the PWR header (see Fig. E) on the ColorDMD circuit board (see Fig. H).

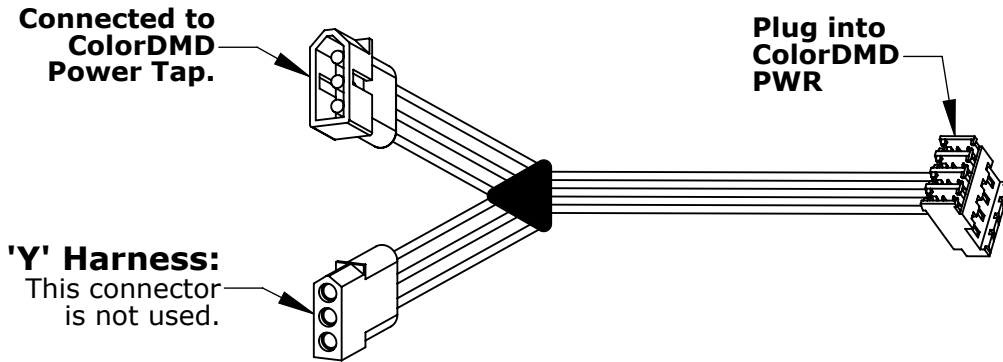

Figure G

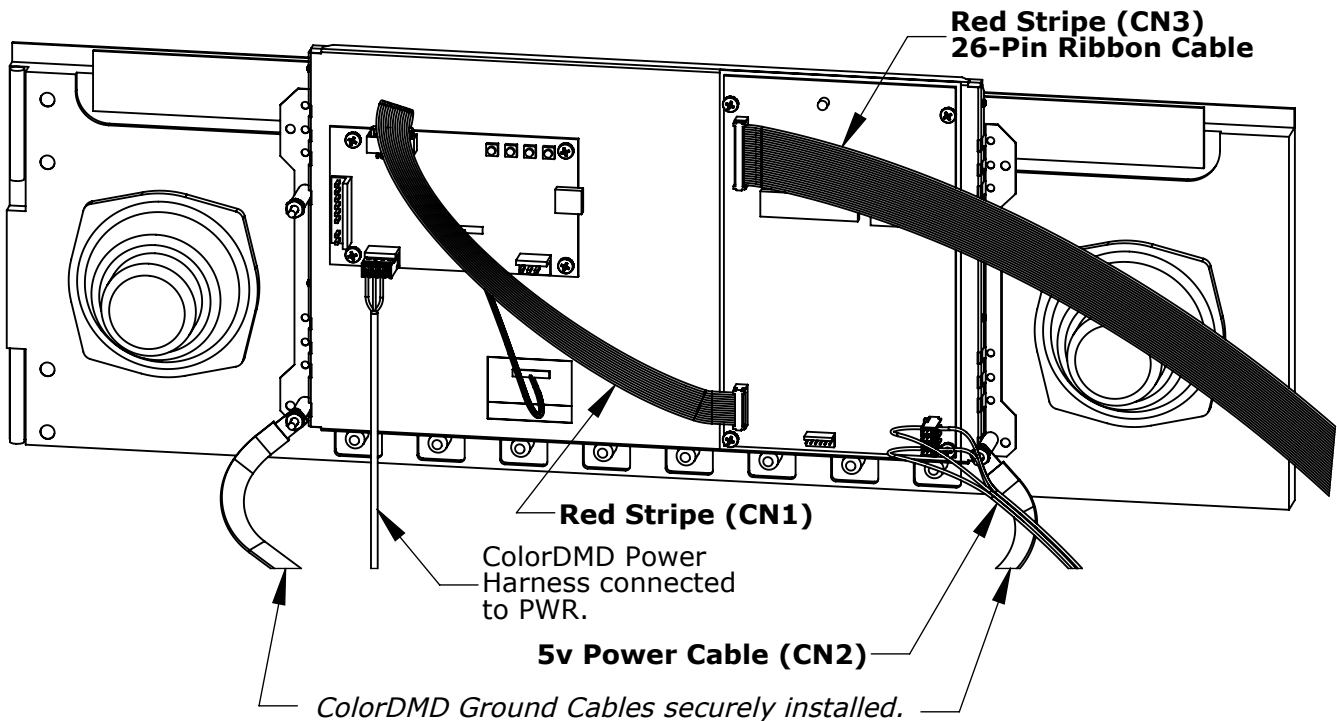

Figure H

TIP

Coil the excess and route the ColorDMD Power Harness along with other existing cables for a clean install.

- STEP **12** Plug the included 12" ColorDMD 14-Pin ribbon cable into DMD_IN on the ColorDMD with the **red stripe on the left-hand side** (see Fig. J). The other end of this cable should be plugged into CN1 on the Display Controller Board with **red stripe facing bottom edge of speaker panel** (See Fig. H).

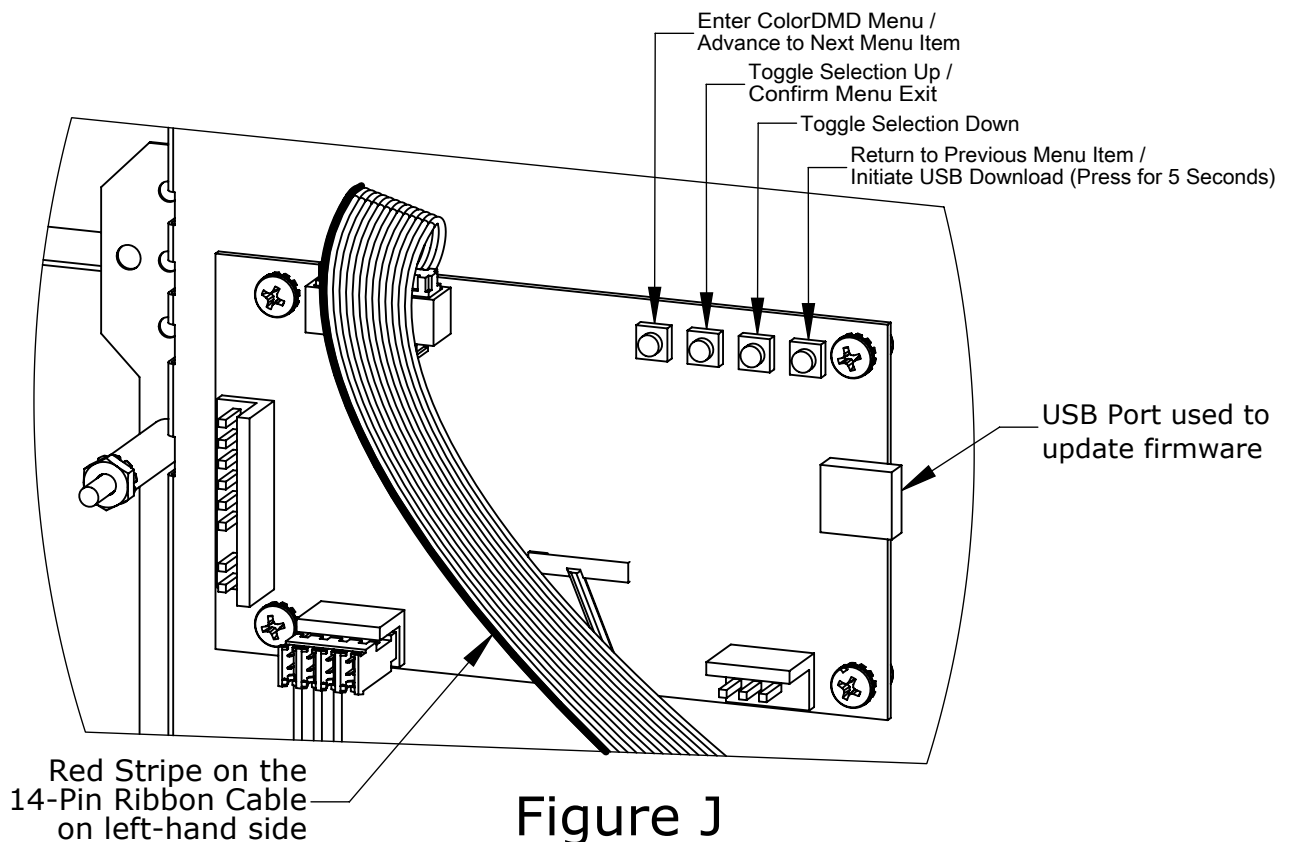

Figure J

- STEP **13** Reconnect the **5v power cable to CN2** and the **26-pin ribbon cable to CN3 with red stripe facing the top edge of the speaker panel** (See Fig. H) to the Display Controller Board .



*Double check for proper alignment of **all** cable connections.*

- STEP **14** While ensuring no wires get pinched, close the speaker panel and turn on the pinball machine.

- STEP **15** Locate and press the right-most *ColorDMD Menu* button (See Fig. J) to customize the display settings. Continue pressing the button to advance to the "MOUNTING" menu. Next use the *Toggle Selection Up* button to change the setting to "WS".

- STEP **16** Press the right-most button to advance to the "EXIT AND SAVE" menu. Press the *Confirm Menu Exit* button to save settings and return to game mode. Video should appear on the new ColorDMD Display. Game is now ready to play. Have fun!

For additional information regarding display settings and updating to a full color ROM file please visit our website at **www.ColorDMD.com**