



ColorDMD LED Display Installation Instructions for **Data East / SEGA**

Congratulations on the purchase of a new ColorDMD display. The ColorDMD will enhance your pinball machine by introducing *color* to the dot matrix display graphics produced by the game.

Tools Required:

- Phillips Screwdriver
- 1/4" Nut Driver



*Be sure to turn **OFF** the power to the pinball machine before installing the ColorDMD LED display.*

STEP **1**

Remove the original DMD from the pinball machine. Insulate the disconnected original DMD high power cable with electrical tape. Also disconnect the 5v power cable at CN2 on the Display Controller Board in the backbox.



WARNING. Electric Shock Hazard - To protect against accidental electric shock, **DO NOT** operate the game without ensuring that the ColorDMD metal bracket is electrically grounded.

STEP **2**

Using the 4 Nylon snap-in PCB posts supplied in the ColorDMD accessory bag, fasten the Display Controller Board to the ColorDMD in the orientation shown in Fig. A. Ensure the RF Shield (if present) remains under the Display Controller Board with metallic side facing down.

STEP **3**

Using the original DMD mounting hardware, install the ColorDMD LED with UP Arrow facing top edge of speaker panel (see Fig. A). *Note: Reattach original ground cables to ColorDMD LED bracket at bare metal mounting screw holes located at the bottom edge.*

STEP **4**

Locate the included ColorDMD Power Tap and Power Harness in the accessory bag. Connect the ColorDMD LED to power. **See Step 5 Data East for Data East games or see Step 5 SEGA for Sega games.**

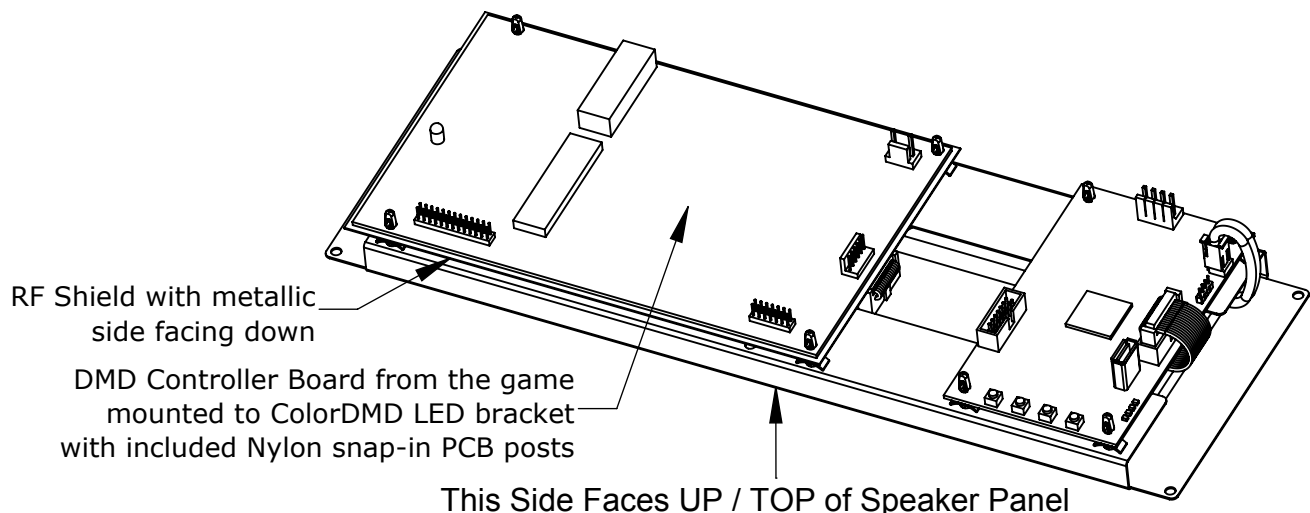

Figure A

STEP **5**

Installing the ColorDMD Power Tap (Data East).

Data East

Temporarily remove the game's 15-pin power cable connector from J16 on the Power Supply Circuit Board located inside the backbox (See Fig. B).

1. Attach the ColorDMD Power Harness to the ColorDMD Power Tap (see Fig. C).
2. Install the ColorDMD Power Tap to J16 (See Fig. C). The ColorDMD Power Tap is keyed and will only install one way.
3. Attach the game's 15-pin power cable connector to the ColorDMD Power Tap (See Fig. C). The 15-pin power cable is keyed and will only install one way.

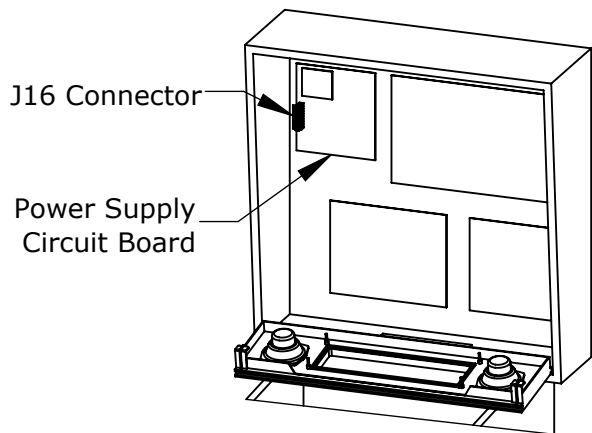

Figure B

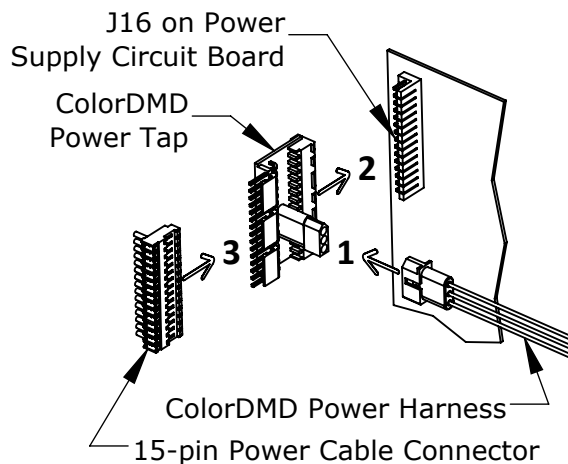

Figure C

STEP **5**

Installing the ColorDMD Power Tap (SEGA).

SEGA

Temporarily remove the game's 15-pin power cable connector from J16 on the Power Supply Circuit Board located inside the backbox (See Fig. D).

1. Attach the ColorDMD Power Harness to the ColorDMD Power Tap (see Fig. E).
2. Install the ColorDMD Power Tap to J16 (See Fig. E). The ColorDMD Power Tap is keyed and will only install one way.
3. Attach the game's 15-pin power cable connector to the ColorDMD Power Tap (See Fig. E). The 15-pin power cable is keyed and will only install one way.

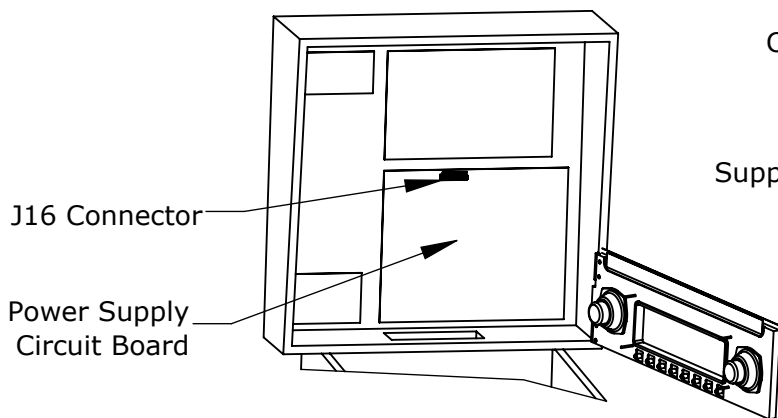

Figure D

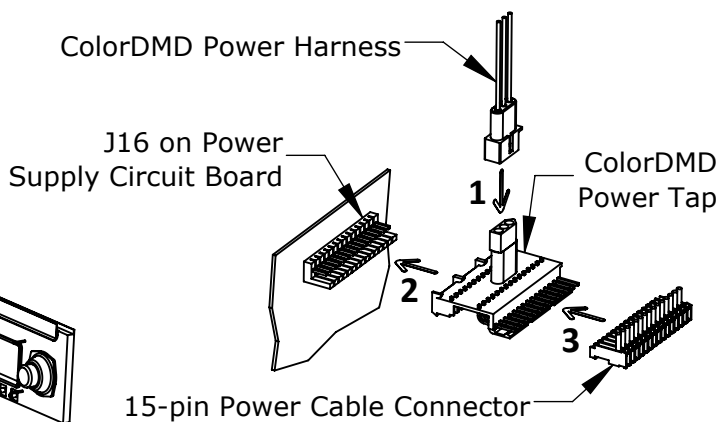

Figure E



Route all power cables to ensure there is no stress on the connections to the ColorDMD Power Tap.

STEP **6**

Locate the ColorDMD Power Harness in the accessory bag. One end of the included ColorDMD Power Harness has a single connector (see Fig. F). Plug this connector into the PWR header on the ColorDMD circuit board (see Fig. G).

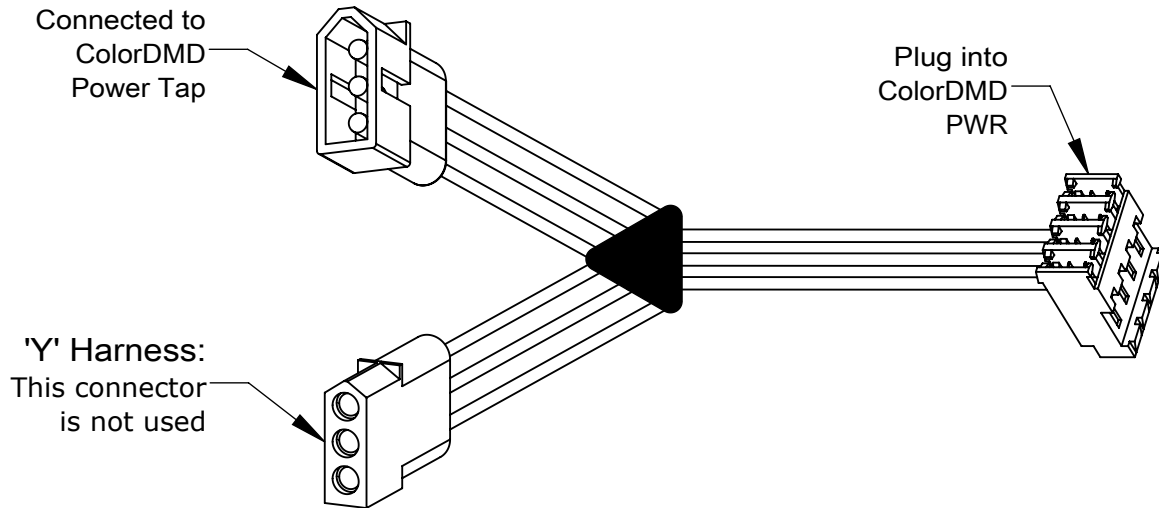

Figure F

STEP **7**

Reconnect the 5v power cable to CN2 and the 26-pin ribbon cable to CN3 with red stripe facing the right-hand side of the to the Display Controller Board.

STEP **8**

Plug the 14-pin ribbon cable into DMD_IN on the ColorDMD LED circuit board with the **red stripe facing the top**. The other end of this cable should still be plugged into CN1 on the Display Controller Board board with **red stripe on the right-hand side**.

TIP

Coil the excess and route the ColorDMD Power Harness along with other existing cables for a clean install.



Double check for proper alignment of **all** cable connections.

STEP **10**

While ensuring no wires get pinched, raise the speaker panel and turn on the pinball machine.

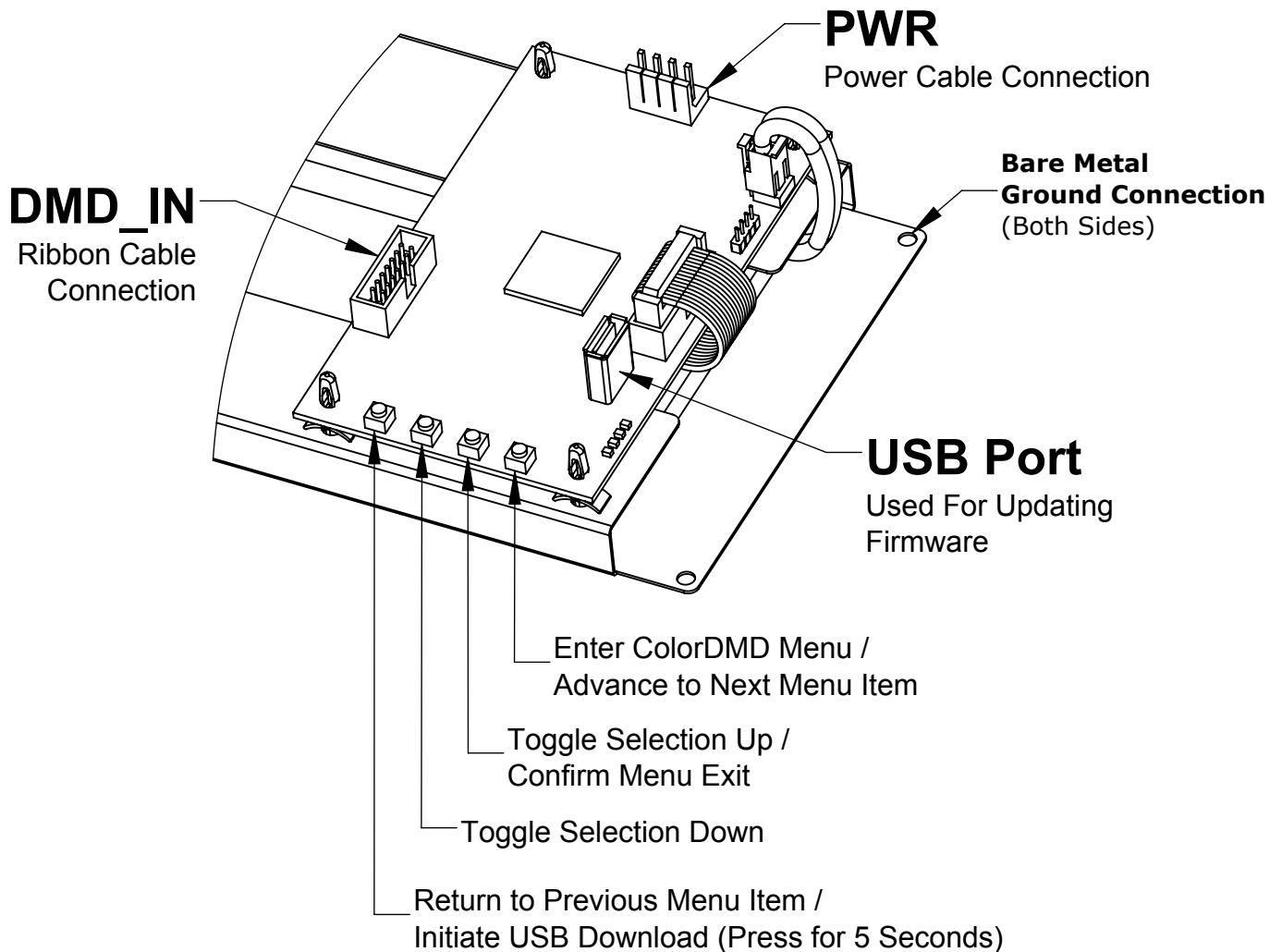

Figure G

STEP **11**

Press the right-most ColorDMD LED push-button to customize the display settings. When finished press the Confirm push-button to "EXIT AND SAVE".

For additional information regarding display settings please visit our website at www.colordmd.com.